

- Compact
- High Flow
- Can be mounted in any position
- Zero pressure drop in operating position
- Unique in-line design
- Compatible with B100 bio-diesel

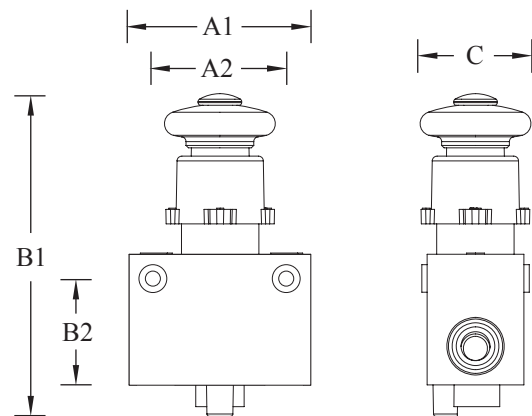
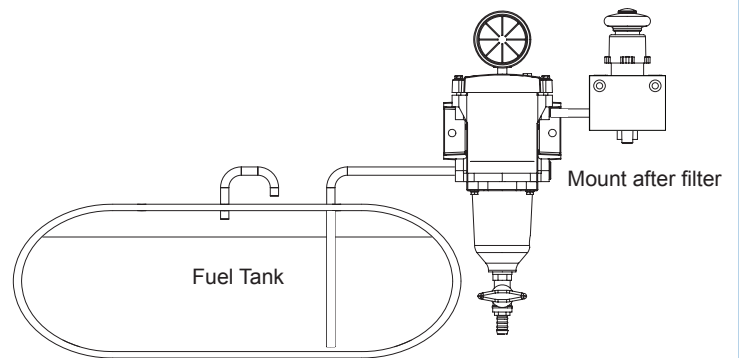
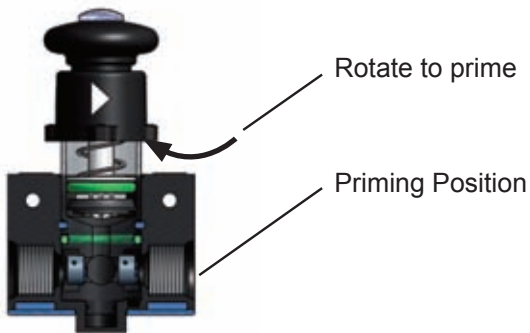
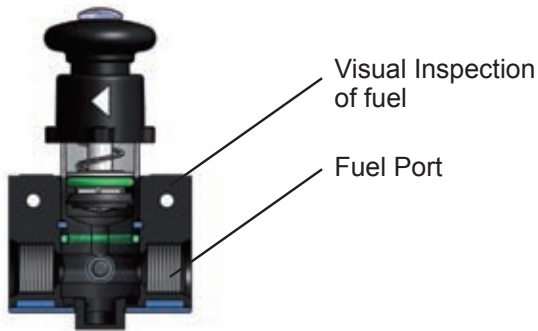

### Technical Specification

Internal Diameter (I.D.)	1/2"
Thread Size	m22 x 1.5
Operating Temp. Range	-40°C to +120°C
Pressure	develops 100 psi (7.5 bar)
Flow	.85 oz (25mL) per stroke

Model	Dimension	
10666	A1	2.95" (74.9 mm)
	A2	2.17" (55.1 mm)
	B1	4.96" (126 mm)
	B2	1.73" (43.9 mm)
	C	1.57" (39.9 mm)

Drawing dimensions for reference only.  
 Technical drawings available upon request.  
 Only use with compatible fluids.

\* Patent pending