

Max. Flow Rate: 630 GPH (2,400 LPH)

- Separ 2000 series water separators fuel filters are a simple solution to many different fuel related problems.
- Five separate stages of filtration ensure 99.9% water separation (Certified TUV Report using SAE J1839) at maximum flow.
- Low restriction reduces wear on fuel pumps and ensures full RPMs.
- Backflushable (cleanable) element reduces down time and costly element changes.



Shown: top 2000/40MK
bottom 2000/40UM

Inlet / Outlet Connections

Single Unit: 1 5/16-12 Straight o-ring SAE
Duplex Unit: Shipped with #20 Male JIC Flare
(other adapters available)
Inlet and Outlet Pipe connection 22mm.

Ordering Specifications

SWK-2000/40 U M MK MS A - G

Duplex _____
Metal bowl _____
Metal bowl w/ contacts _____
Metal bowl w/ potential-free probe _____
for water level indication
Automatic switchable duplex _____
(See page 18 for details)
Gauge _____

We reserve the right to alter the specification without prior notice.

Pressure Drop

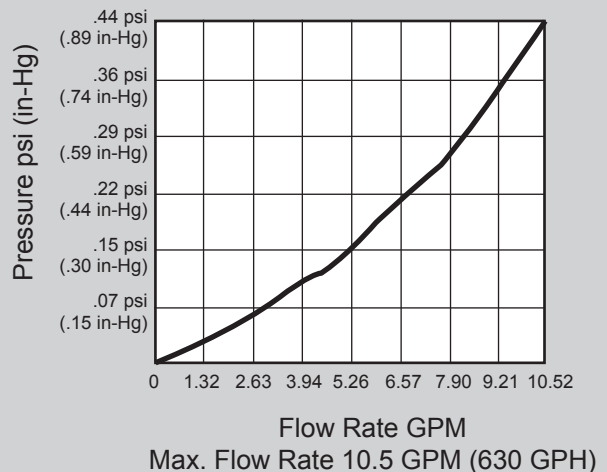

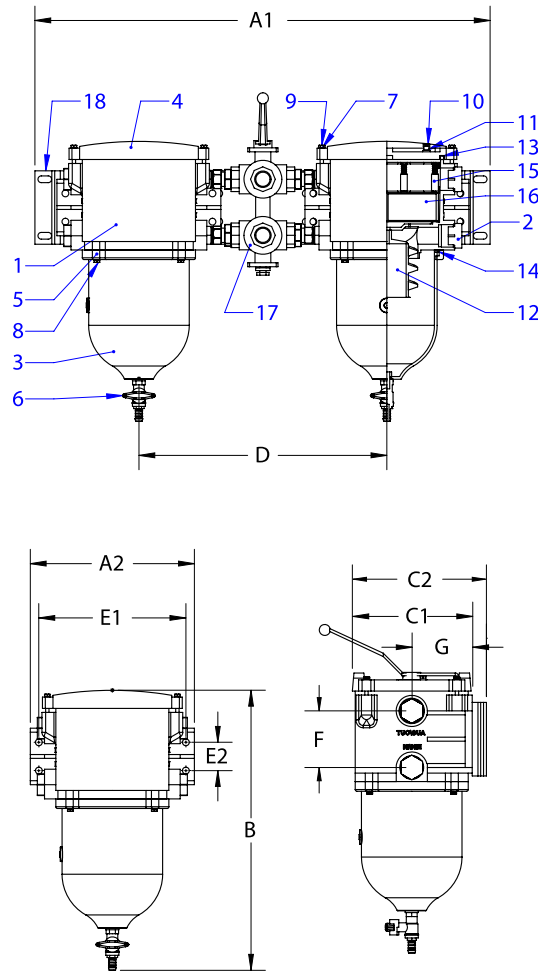

Item	Part #	Description	Dimension							
1	10049	Filter Housing	A1	31.69" (805mm)						
2	BI 6408-16-0	1" Hex Plug	A2	11.42" (290mm)						
3	30457	Bowl	B	19.49" (495.1mm)						
4	30435	Lid	C1	8.35" (212mm)						
5	30446	Retainer Ring	C2	9.34" (237.2mm)						
6	30456	Drain Valve	D	17.22" (437.5mm)						
7	30447	Washer	E1	10.24" (260mm)						
8	30568	Bowl Screw	E2	1.97" (50mm)						
9	30404	Lid Screw	F	3.94" (100mm)						
10	30408	Bleed Screw	G	4.21" (107mm)						
11	30558	Bleed Screw Gasket	<table border="1"> <thead> <tr> <th>Model</th> <th>Weight</th> </tr> </thead> <tbody> <tr> <td>SWK-2000/40M</td> <td>24.5 lbs (11.11 kg)</td> </tr> <tr> <td>SWK-2000/40UM</td> <td>68 lbs (30.84 kg)</td> </tr> </tbody> </table>		Model	Weight	SWK-2000/40M	24.5 lbs (11.11 kg)	SWK-2000/40UM	68 lbs (30.84 kg)
Model	Weight									
SWK-2000/40M	24.5 lbs (11.11 kg)									
SWK-2000/40UM	68 lbs (30.84 kg)									
12	30438	Centrifuge								
13	30440	Lid Gasket								
14	30442	Bowl Gasket								
15	30299	Spring Frame								
16	04010	Filter Element								
	04030	10 Micron								
	04060S	30 Micron (Standard)								
	30467	60 Micron (stainless steel)								
17	30467	Reversing Valve Assembly								
18	30470	Mounting Bracket								