

Max. Flow Rate: 2,060 GPH (7,800 LPH)

- Separ 2000 series water separators fuel filters are a simple solution to many different fuel related problems.
- Five separate stages of filtration ensure 99.9% water separation (Certified TUV Report using SAE J1839) at maximum flow.
- Low restriction reduces wear on fuel pumps and ensures full RPMs.
- Backflushable (cleanable) element reduces down time and costly element changes.



Shown: top 2000/130MK-G  
bottom 2000/130UMK-G

### Inlet / Outlet Connections

Single Unit: 2" NPT Pipe  
Duplex Unit: 2" FNPT (other adapters available)  
Inlet and Outlet Pipe connection 2" NPT.

### Ordering Specifications

SWK-2000/130 U MK MS A - G

Duplex \_\_\_\_\_  
Metal bowl w/ contacts \_\_\_\_\_  
Metal bowl w/ potential-free probe \_\_\_\_\_  
for water level indication  
Automatic switchable duplex \_\_\_\_\_  
(See page 18 for details)  
Gauge \_\_\_\_\_

We reserve the right to alter the specification without prior notice.

### Pressure Drop

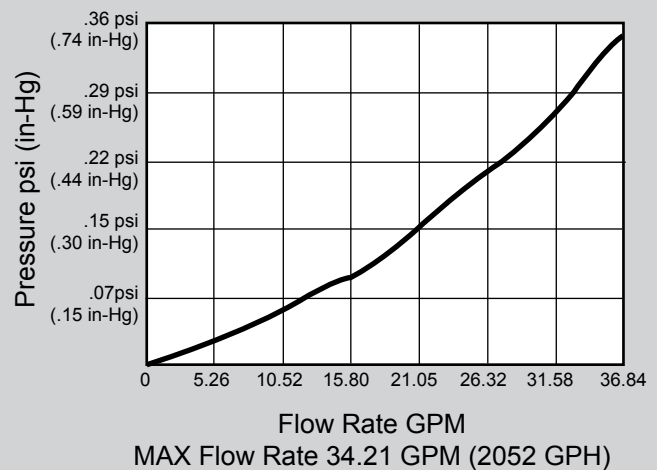

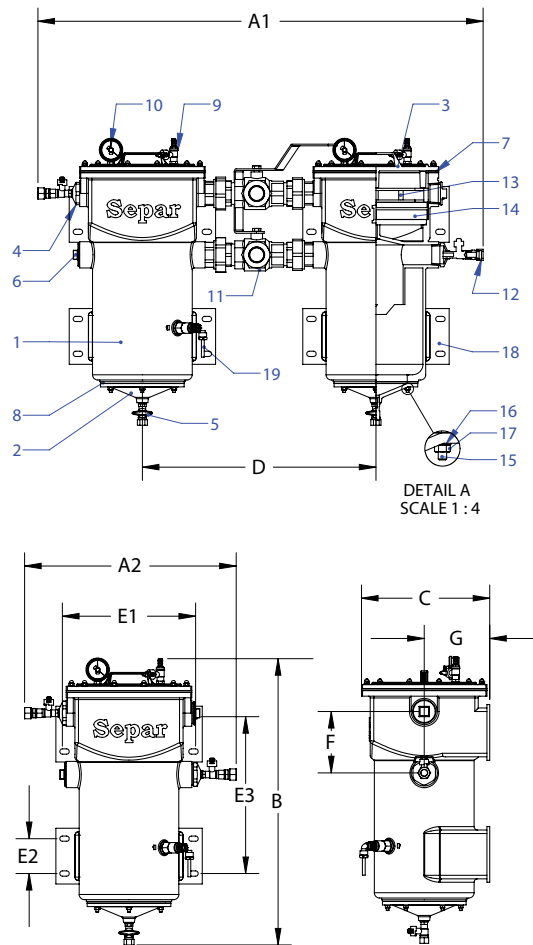

Item	Part #	Description	Dimension	
1	10133	Housing	A1	47.56" (1208mm)
2	10135	Bowl	A2	23.9" (607.4mm)
3	10050	Lid	B	32.34" (821.5mm)
4	10058	2" BSP Fitting	C	14.49" (368mm)
5	30456	Drain Valve	D	26.38" (670mm)
6	10053	2" BSP Plug	E1	15.04" (382mm)
7	30387	Lid Gasket	E2	3.94" (100mm)
8	10136	Bowl Gasket	E3	17.72"(450mm)
9	30366	Bleed Valve	F	6.93" (176mm)
10	30650	Vacuum Gauge	G	7.4" (188mm)
11	10043	Reversing Valve Assembly		
12	10062	Reducing Bushing		
13	30298	Spring Frame		
14	01810 01830 01860S	Filter Element 10 Micron 30 Micron (Standard) 60 Micron (stainless steel)		
15	10072	Stud Screw	<b>Model</b>	<b>Weight</b>
16	30021	Washer	SWK-2000/130MK	105 lbs (47.63 kg)
17	10073	Cap Nut	SWK-2000/130UMK	250 lbs (113.4 kg)
18	10129	Mounting Bracket		
19	30402	Water Sensor		