

Max. Flow Rate: 79 GPH (300 LPH)

- Separ 2000 series water separators fuel filters are a simple solution to many different fuel related problems.
- Five separate stages of filtration ensure 99.9% water separation (Certified TUV Report using SAE J1839) at maximum flow.
- Low restriction reduces wear on fuel pumps and ensures full RPMs.
- Backflushable (cleanable) element reduces down time and costly element changes.
- Marine version with U.S. Coast Guard-accepted metal heat deflector.

INDUSTRIAL



MARINE



Shown: Industrial (left to right) 2000/5/50, 2000/5/50U
Marine (left to right) 2000/5/50D, 2000/5/50UD-G

Inlet / Outlet Connections

Single Unit: 3/4"-16 Straight o-ring SAE
Duplex Unit: Shipped with #8 Male JIC Flare
(other adapters available)
Inlet and Outlet Pipe connection 12mm.

Ordering Specifications

SWK-2000/5/50 U M MK K KD D A - G

Duplex _____
Metal bowl _____
Metal bowl w/ contacts _____
Clear bowl w/ water contacts _____
Clear bowl w/ metal heat deflector _____
and water contacts _____
Clear bowl w/ metal heat deflector _____
Automatic switchable duplex _____
(See page 18 for details)
Gauge _____

We reserve the right to alter the specification without prior notice.

Pressure Drop

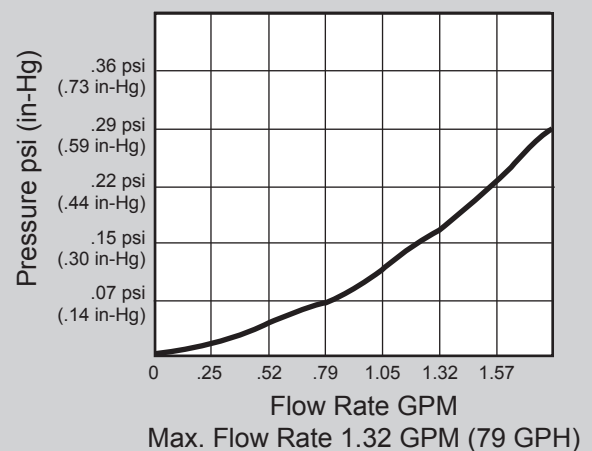

INDUSTRIAL

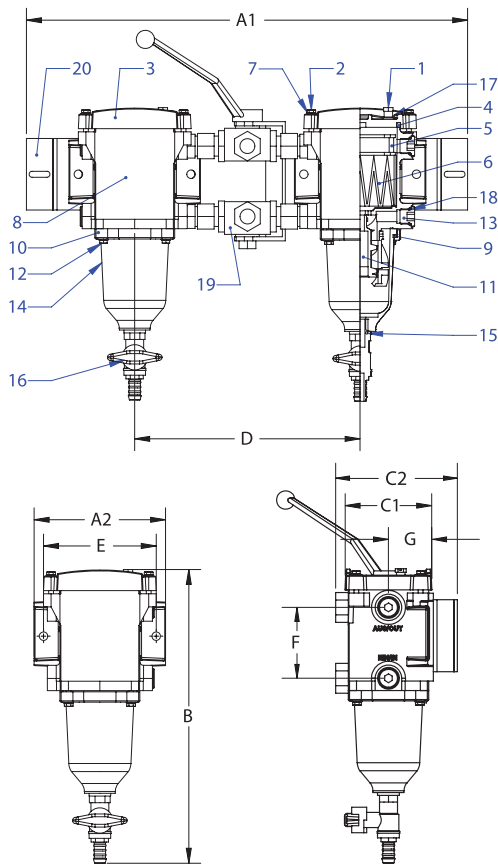

MARINE

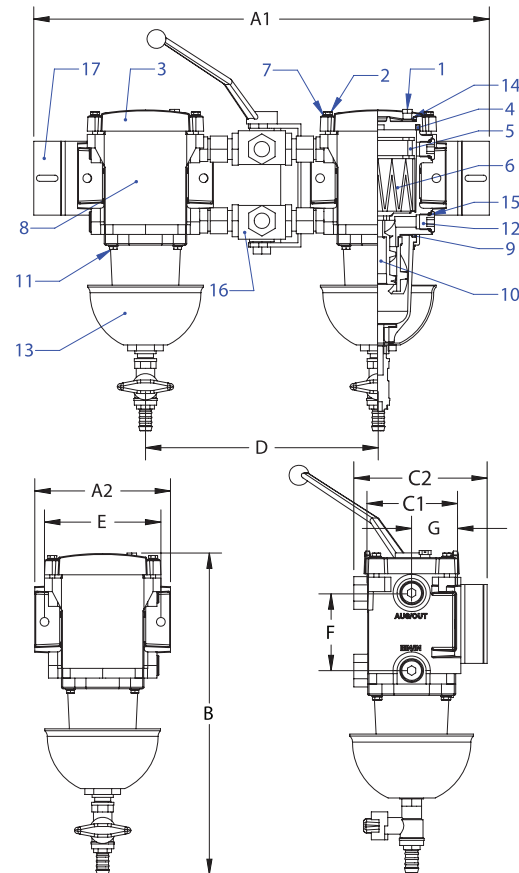

Item	Part #	Description	Dimension		Item	Part #	Description	Dimension	
1	30408	Bleed Screw	A1	18.5"	1	30408	Bleed Screw	A1	18.5"
2	FAB51821	Lid Screw		(469.9mm)	2	FAB-51821	Lid Screw		(469.9mm)
3	30542	Lid	A2	5.51"	3	30542	Lid	A2	5.51"
4	10367	Lid Gasket		(140mm)	4	10367	Lid Gasket		(140mm)
5	30295	Spring Frame	B	12.31"	5	30295	Spring Frame	B	12.31"
6		Filter Element		(312.8mm)	6		Filter Element		(312.8mm)
	00510/50	10 Micron	C1	3.68"		00510/50	10 Micron	C1	3.68"
	00530/50	30 Micron (standard)		(93.5mm)		00530/50	30 Micron (standard)		(93.5mm)
	00560/50S	60 Micron (stainless steel)	C2	5.07"		00560/50S	60 Micron (stainless steel)	C2	4.72"
7	30447	Washer		(128.8mm)	7	30447	Washer		(120mm)
8	30380	Housing	D	9.45"	8	30380	Housing	D	9.45"
9	10366	Bowl Gasket		(240.14mm)	9	10366	Bowl Gasket		(240.14mm)
10	30564	Retainer Ring	E	4.72"	10	30548	Centrifuge	E	4.72"
11	30548	Centrifuge		(120mm)	11	30561	Bowl Screw		(120mm)
12	30561	Bowl Screw	F	2.95"	12	6408-08	Plug	F	2.95"
13	6408-08	Plug		(75mm)	13		Bowl Assembly	G	1.87"
14	30984	Clear Bowl	G	1.87"		30988W	Single unit (white)		(47.5mm)
15	10360	Drain Valve O-Ring		(47.5mm)		30988	Duplex unit (grey)		
16	30366	Drain Valve	Model Weight		14	30558	Bleed Screw Gasket	Model Weight	
17	30558	Bleed Screw Gasket	SWK-2000/5/50	3.5 lbs	15	6408-08	Plug O-Ring	SWK-2000/5/50D	4.5 lbs
18	6408-08	Plug O-Ring		(1.59 kg)	16	30474	Reversing Valve Assembly		(2.04 kg)
19	30474	Reversing Valve Assembly	SWK-2000/5/50U	12 lbs	17	30476	Mounting Bracket	SWK-2000/5/50UD	13.5 lbs
20	30476	Mounting Bracket		(5.44 kg)					(6.12 kg)